

ILNAS

Institut luxembourgeois de la normalisation
de l'accréditation, de la sécurité et qualité
des produits et services

ILNAS-EN 16723-1:2016

**Natural gas and biomethane for use in
transport and biomethane for injection
in the natural gas network - Part 1:
Specifications for biomethane for**

Gaz naturel et biométhane pour
utilisation dans le transport et
biométhane pour injection dans les
réseaux de gaz naturel - Partie 1 -

Erdgas und Biomethan zur Verwendung
im Transportwesen und Biomethan zur
Einspeisung ins Erdgasnetz - Teil 1:
Festlegungen für Biomethan zur

11/2016



National Foreword

This European Standard EN 16723-1:2016 was adopted as Luxembourgish Standard ILNAS-EN 16723-1:2016.

Every interested party, which is member of an organization based in Luxembourg, can participate for FREE in the development of Luxembourgish (ILNAS), European (CEN, CENELEC) and International (ISO, IEC) standards:

- Participate in the design of standards
- Foresee future developments
- Participate in technical committee meetings

<https://portail-qualite.public.lu/fr/normes-normalisation/participer-normalisation.html>

THIS PUBLICATION IS COPYRIGHT PROTECTED

Nothing from this publication may be reproduced or utilized in any form or by any mean - electronic, mechanical, photocopying or any other data carries without prior permission!

ICS 27.190

English Version

Natural gas and biomethane for use in transport and biomethane for injection in the natural gas network - Part 1: Specifications for biomethane for injection in the natural gas network

Gaz naturel et biométhane pour utilisation dans le transport et biométhane pour injection dans les réseaux de gaz naturel - Partie 1 - Spécifications du biométhane pour injection dans les réseaux de gaz naturel

Erdgas und Biomethan zur Verwendung im Transportwesen und Biomethan zur Einspeisung ins Erdgasnetz - Teil 1: Festlegungen für Biomethan zur Einspeisung ins Erdgasnetz

This European Standard was approved by CEN on 17 September 2016.

CEN members are bound to comply with the CEN/CENELEC Internal Regulations which stipulate the conditions for giving this European Standard the status of a national standard without any alteration. Up-to-date lists and bibliographical references concerning such national standards may be obtained on application to the CEN-CENELEC Management Centre or to any CEN member.

This European Standard exists in three official versions (English, French, German). A version in any other language made by translation under the responsibility of a CEN member into its own language and notified to the CEN-CENELEC Management Centre has the same status as the official versions.

CEN members are the national standards bodies of Austria, Belgium, Bulgaria, Croatia, Cyprus, Czech Republic, Denmark, Estonia, Finland, Former Yugoslav Republic of Macedonia, France, Germany, Greece, Hungary, Iceland, Ireland, Italy, Latvia, Lithuania, Luxembourg, Malta, Netherlands, Norway, Poland, Portugal, Romania, Slovakia, Slovenia, Spain, Sweden, Switzerland, Turkey and United Kingdom.



EUROPEAN COMMITTEE FOR STANDARDIZATION
COMITÉ EUROPÉEN DE NORMALISATION
EUROPÄISCHES KOMITEE FÜR NORMUNG

CEN-CENELEC Management Centre: Avenue Marnix 17, B-1000 Brussels

Contents	Page
European foreword.....	3
Introduction	4
1 Scope.....	6
2 Normative references.....	6
3 Terms and definitions	6
4 Parameters and test methods.....	8
4.1 General.....	8
4.2 Standard reference conditions.....	8
4.3 Applicable requirements and test methods for biomethane for injection in the natural gas network.....	8
5 Sampling.....	10
Annex A (informative) Parameters.....	11
A.1 Total silicon.....	11
A.2 Hydrogen.....	11
A.3 Compressor oil, dust impurities and biogenic materials	11
A.4 Water and hydrocarbon dew point temperature.....	12
Annex B (informative) Odorization and sulfur.....	13
B.1 CEN/TC 408 approach	13
B.2 General.....	13
B.3 Total sulfur from Odorants.....	13
Annex C (informative) Examples of different compliance schemes.....	14
C.1 General.....	14
C.2 General prescriptions.....	14
C.2.1 Permit conditions.....	14
C.2.2 Upgrading plants.....	14
C.2.3 Control and monitoring	14
C.2.4 Measurement.....	15
C.2.5 Risk assessment.....	15
C.3 Common practices	15
Annex D (informative) A-deviations.....	18
Bibliography.....	19

European foreword

This document (EN 16723-1:2016) has been prepared by Technical Committee CEN/TC 408 “Natural gas and biomethane for use in transport and biomethane for injection in the natural gas network”, the secretariat of which is held by AFNOR.

This European Standard shall be given the status of a national standard, either by publication of an identical text or by endorsement, at the latest by May 2017, and conflicting national standards shall be withdrawn at the latest by May 2017.

Attention is drawn to the possibility that some of the elements of this document may be the subject of patent rights. CEN shall not be held responsible for identifying any or all such patent rights.

This document has been prepared under a mandate given to CEN by the European Commission and the European Free Trade Association.

EN 16723 consists of the following parts, under the general title “Natural gas and biomethane for use in transport and biomethane for injection in the natural gas network”:

- *Part 1: Specifications for biomethane for injection in the natural gas network*
- *Part 2: Automotive fuel specifications*

According to the CEN-CENELEC Internal Regulations, the national standards organisations of the following countries are bound to implement this European Standard: Austria, Belgium, Bulgaria, Croatia, Cyprus, Czech Republic, Denmark, Estonia, Finland, Former Yugoslav Republic of Macedonia, France, Germany, Greece, Hungary, Iceland, Ireland, Italy, Latvia, Lithuania, Luxembourg, Malta, Netherlands, Norway, Poland, Portugal, Romania, Slovakia, Slovenia, Spain, Sweden, Switzerland, Turkey and the United Kingdom.

Introduction

This European Standard was prepared by CEN/TC 408 in response to the European Commission standardization mandate M/475.

The Mandate asks for the development of a set of quality specifications for biomethane to be used as a fuel for vehicle engines and to be injected in natural gas pipelines (network).

However, the scope of the standard was widened according to BT decision C109/2012 that redefined the scope of CEN/TC 408: "Standardization of specifications for natural gas and biomethane as vehicle fuel and of biomethane for injection in the natural gas grid, including any necessary related methods of analysis and testing. Production process, source and the origin of the source are excluded".

NOTE The CEN Technical Board (CEN/BT) is responsible to coordinate the work between technical bodies in order to achieve a coherent set of standards and to avoid overlaps.

One of the aims of European policy in the field of energy is to increase the security of energy supply in the EU as well as to contribute to reduce the emission of greenhouse gases accepted by the EU at Kyoto. In this context, a special focus is given to the development and use of energy from renewable sources.

Directive 2009/28/EC on the promotion of the use of energy from renewable sources and amending and subsequently repealing Directives 2001/77/EC and 2003/30/EC stipulates clear aims regarding the percentage of renewables in EU energy consumption and states the related need to support the integration of energy from renewable sources into the energy networks including the establishment of appropriate technical rules in line with Directive 2003/55/EC (Article 6) replaced by 2009/73/EC (Article 8) for the realization of the competitive single European Gas Market and the technical interoperability of gas networks, (network connection, gas quality, gas odorization and gas pressure requirements).

Supporting the EU policy and therefore the maximization of the production and use of biomethane and considering the absence of standards the European Commission DG ENER has included the injection of biomethane in natural gas pipelines in Mandate M/475. Biomethane in this context can be produced from biological (fermentation, digestion ...) and thermochemical processing of biomass and is appropriate to be used as a blending component to natural gas. A special focus is given to the development and use of energy from renewable sources of biological and non-biological origin. Other gases complying with this standard can be injected.

Figure 1 provides a visual representation of some applications of biomethane.

Mandate M/475 indicates that the requirements for natural gas quality for injection in the natural gas network are developed by CEN/TC 234 in answer to Mandate M/400 on natural gas quality. CEN/TC 408 should consider the work of the pending mandate M/400 on gas quality, and should refer to the parameters as defined and specified in EN 16726. This standard should exclude the definition of any parameters or substances that are addressed in EN 16726. However, it may specify more strict limits for parameters or substances unique to biomethane if deemed technically necessary. If needed, additional parameters or substances should be defined.

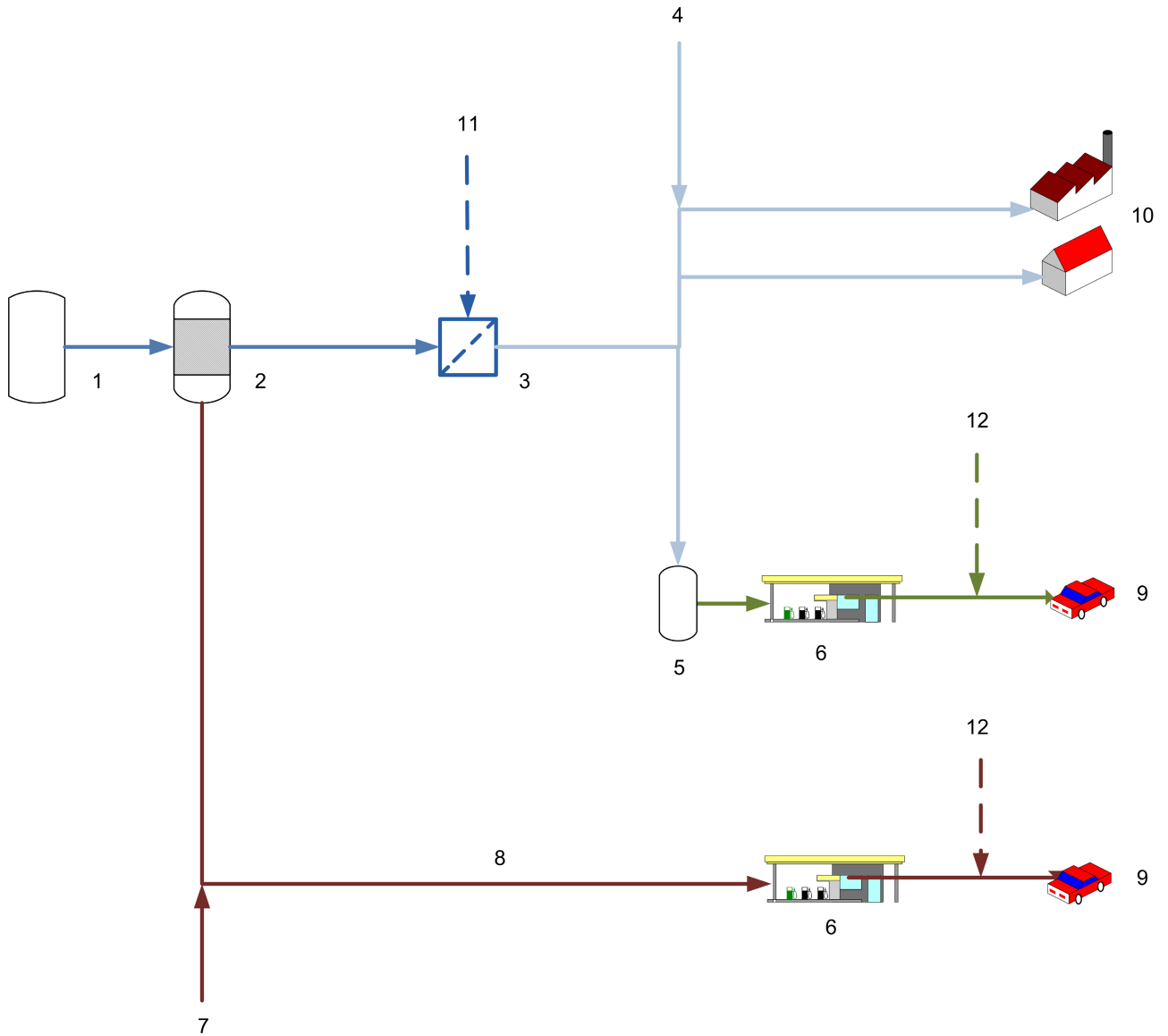

Key

- | | | | |
|---|---------------------------------------------------|----|----------------------------------|
| 1 | biogas from digestion or thermos chemical process | 7 | non-grid sourced natural gas |
| 2 | upgrading | 8 | local dedicated infrastructure |
| 3 | injection into the gas grid | 9 | automotive use |
| 4 | natural gas grid | 10 | domestic and industrial use |
| 5 | conditioning | 11 | Part 1: grid specification |
| 6 | refuelling station | 12 | Part 2: automotive specification |

Figure 1 — Representation of some flows and uses of biomethane and natural gas

1 Scope

This European Standard specifies the requirements and test methods for biomethane at the point of entry into natural gas networks.

2 Normative references

The following documents, in whole or in part, are normatively referenced in this document and are indispensable for its application. For dated references, only the edition cited applies. For undated references, the latest edition of the referenced document (including any amendments) applies.

EN 16726:2015, *Gas infrastructure - Quality of gas - Group H*

EN ISO 10715:2000, *Natural gas - Sampling guidelines (ISO 10715:1997)*

EN ISO 13443:2005, *Natural gas - Standard reference conditions (ISO 13443:1996 including Corrigendum 1:1997)*

3 Terms and definitions

For the purposes of this document, the terms and definitions given in EN 16726:2015 and the following apply.

3.1 biogas

gas, comprising principally methane and carbon dioxide, obtained from the anaerobic digestion of biomass

3.2 biomass

biological material from living, or recently living organisms, typically this may be plants or plant-derived materials

3.3 biomethane

gas comprising principally methane, obtained from either upgrading of biogas or methanation of bio-syngas

3.4 bio-syngas

gas, comprising principally carbon monoxide and hydrogen, obtained from gasification of biomass

3.5 gas infrastructure

pipeline systems including pipework, underground gas storages and their associated stations or plants for the transmission and distribution of gas

3.6 hydrocarbon dew point temperature

temperature above which no condensation of hydrocarbons occurs at a specified pressure

3.7 lower heating value

amount of heat that would be released by the complete combustion with oxygen of a specified quantity of gas, in such a way that the pressure at which the reaction takes place remains constant, and all the products of combustion are returned to the same specified temperature as that of the reactants, all of these products being in the gaseous state