

INTERNATIONAL STANDARD

NORME INTERNATIONALE

**Wind turbines –
Part 27-1: Electrical simulation models – Wind turbines**

**Eoliennes –
Partie 27-1: Modèles de simulation électrique – Eoliennes**



THIS PUBLICATION IS COPYRIGHT PROTECTED
Copyright © 2015 IEC, Geneva, Switzerland

All rights reserved. Unless otherwise specified, no part of this publication may be reproduced or utilized in any form or by any means, electronic or mechanical, including photocopying and microfilm, without permission in writing from either IEC or IEC's member National Committee in the country of the requester. If you have any questions about IEC copyright or have an enquiry about obtaining additional rights to this publication, please contact the address below or your local IEC member National Committee for further information.

Droits de reproduction réservés. Sauf indication contraire, aucune partie de cette publication ne peut être reproduite ni utilisée sous quelque forme que ce soit et par aucun procédé, électronique ou mécanique, y compris la photocopie et les microfilms, sans l'accord écrit de l'IEC ou du Comité national de l'IEC du pays du demandeur. Si vous avez des questions sur le copyright de l'IEC ou si vous désirez obtenir des droits supplémentaires sur cette publication, utilisez les coordonnées ci-après ou contactez le Comité national de l'IEC de votre pays de résidence.

IEC Central Office
3, rue de Varembe
CH-1211 Geneva 20
Switzerland

Tel.: +41 22 919 02 11
Fax: +41 22 919 03 00
info@iec.ch
www.iec.ch

About the IEC

The International Electrotechnical Commission (IEC) is the leading global organization that prepares and publishes International Standards for all electrical, electronic and related technologies.

About IEC publications

The technical content of IEC publications is kept under constant review by the IEC. Please make sure that you have the latest edition, a corrigenda or an amendment might have been published.

IEC Catalogue - webstore.iec.ch/catalogue

The stand-alone application for consulting the entire bibliographical information on IEC International Standards, Technical Specifications, Technical Reports and other documents. Available for PC, Mac OS, Android Tablets and iPad.

IEC publications search - www.iec.ch/searchpub

The advanced search enables to find IEC publications by a variety of criteria (reference number, text, technical committee,...). It also gives information on projects, replaced and withdrawn publications.

IEC Just Published - webstore.iec.ch/justpublished

Stay up to date on all new IEC publications. Just Published details all new publications released. Available online and also once a month by email.

Electropedia - www.electropedia.org

The world's leading online dictionary of electronic and electrical terms containing more than 30 000 terms and definitions in English and French, with equivalent terms in 15 additional languages. Also known as the International Electrotechnical Vocabulary (IEV) online.

IEC Glossary - std.iec.ch/glossary

More than 60 000 electrotechnical terminology entries in English and French extracted from the Terms and Definitions clause of IEC publications issued since 2002. Some entries have been collected from earlier publications of IEC TC 37, 77, 86 and CISPR.

IEC Customer Service Centre - webstore.iec.ch/csc

If you wish to give us your feedback on this publication or need further assistance, please contact the Customer Service Centre: csc@iec.ch.

A propos de l'IEC

La Commission Electrotechnique Internationale (IEC) est la première organisation mondiale qui élabore et publie des Normes internationales pour tout ce qui a trait à l'électricité, à l'électronique et aux technologies apparentées.

A propos des publications IEC

Le contenu technique des publications IEC est constamment revu. Veuillez vous assurer que vous possédez l'édition la plus récente, un corrigendum ou amendement peut avoir été publié.

Catalogue IEC - webstore.iec.ch/catalogue

Application autonome pour consulter tous les renseignements bibliographiques sur les Normes internationales, Spécifications techniques, Rapports techniques et autres documents de l'IEC. Disponible pour PC, Mac OS, tablettes Android et iPad.

Recherche de publications IEC - www.iec.ch/searchpub

La recherche avancée permet de trouver des publications IEC en utilisant différents critères (numéro de référence, texte, comité d'études,...). Elle donne aussi des informations sur les projets et les publications remplacées ou retirées.

IEC Just Published - webstore.iec.ch/justpublished

Restez informé sur les nouvelles publications IEC. Just Published détaille les nouvelles publications parues. Disponible en ligne et aussi une fois par mois par email.

Electropedia - www.electropedia.org

Le premier dictionnaire en ligne de termes électroniques et électriques. Il contient plus de 30 000 termes et définitions en anglais et en français, ainsi que les termes équivalents dans 15 langues additionnelles. Egalement appelé Vocabulaire Electrotechnique International (IEV) en ligne.

Glossaire IEC - std.iec.ch/glossary

Plus de 60 000 entrées terminologiques électrotechniques, en anglais et en français, extraites des articles Termes et Définitions des publications IEC parues depuis 2002. Plus certaines entrées antérieures extraites des publications des CE 37, 77, 86 et CISPR de l'IEC.

Service Clients - webstore.iec.ch/csc

Si vous désirez nous donner des commentaires sur cette publication ou si vous avez des questions contactez-nous: csc@iec.ch.

INTERNATIONAL STANDARD

NORME INTERNATIONALE



**Wind turbines –
Part 27-1: Electrical simulation models – Wind turbines**

**Eoliennes –
Partie 27-1: Modèles de simulation électrique – Eoliennes**

INTERNATIONAL
ELECTROTECHNICAL
COMMISSION

COMMISSION
ELECTROTECHNIQUE
INTERNATIONALE

ICS 27.180

ISBN 978-2-8322-2226-3

**Warning! Make sure that you obtained this publication from an authorized distributor.
Attention! Veuillez vous assurer que vous avez obtenu cette publication via un distributeur agréé.**

CONTENTS

FOREWORD.....	7
INTRODUCTION.....	9
1 Scope.....	12
2 Normative references	12
3 Terms, definitions, abbreviations and subscripts.....	12
3.1 Terms and definitions.....	12
3.2 Abbreviations and subscripts	17
3.2.1 Abbreviations.....	17
3.2.2 Subscripts	18
4 Symbols and units	19
4.1 General.....	19
4.2 Symbols (units).....	19
5 Specification of models.....	21
5.1 Overview.....	21
5.2 General specifications.....	21
5.3 Model interface	23
5.4 Parameters and initialisation.....	24
5.4.1 General	24
5.4.2 Parameter categories	24
5.4.3 Global parameters	24
5.4.4 Initialisation.....	24
5.5 Modular structure of models.....	25
5.5.1 Generic modular structure	25
5.5.2 Type 1	26
5.5.3 Type 2.....	28
5.5.4 Type 3.....	30
5.5.5 Type 4.....	33
5.6 Module library	37
5.6.1 Aerodynamic models	37
5.6.2 Mechanical models	38
5.6.3 Generator set models	39
5.6.4 Electrical equipment	44
5.6.5 Control models	44
5.6.6 Grid protection model	55
6 Specification of validation procedure	57
6.1 Overview.....	57
6.2 General specifications.....	58
6.3 Validation procedure	59
6.3.1 Voltage dips	59
6.3.2 Reference point changes	64
6.3.3 Grid protection.....	64
Annex A (informative) Validation test documentation.....	66
A.1 General.....	66
A.2 Simulation model and validation setup information	66
A.3 Template for validation test results	66

A.3.1	General	66
A.3.2	Voltage dips	67
A.3.3	Reference point changes	67
A.3.4	Grid protection.....	68
Annex B (normative)	Limits to possible model accuracy	69
B.1	General.....	69
B.2	Inevitable simulation errors	69
B.3	Measurement errors.....	69
Annex C (normative)	Digital 2 nd order critically damped low pass filter	71
Annex D (informative)	Simplified plant level model.....	72
D.1	General.....	72
D.2	Area of application	72
D.3	Voltage and reactive power controller model description	72
D.4	Frequency and active power controller model description.....	74
Annex E (informative)	Two-dimensional aerodynamic model.....	76
E.1	Objective	76
E.2	Model approach	76
E.3	Model parameter fits	77
E.4	Use cases	80
E.4.1	General	80
E.4.2	Stability study use cases.....	80
E.4.3	Validation use cases.....	80
E.5	Model initialisation at derated conditions.....	80
Annex F (informative)	Generic Software Interface for use of models in different software environments.....	81
F.1	Description of the approach	81
F.2	Description of the Software interface	82
F.2.1	Description of data structures	82
F.2.2	Functions for communication through the ESE-interface.....	83
F.2.3	Inputs, Outputs, Parameters	85
Annex G (normative)	Block symbol library.....	86
G.1	General.....	86
G.2	Time step delay.....	86
G.3	Stand-alone ramp rate limiter.....	86
G.4	First order filter with absolute limits, rate limits and freeze flag	87
G.5	Lookup table	88
G.6	Comparator.....	88
G.7	Timer	88
G.8	Anti windup integrator	89
G.9	Integrator with reset.....	90
G.10	First order filter with limitation detection.....	90
G.11	Delay flag	91
G.12	Raising edge detection	91
Bibliography.....		93

Figure 1 – Classification of power system stability according to IEEE/CIGRE Joint Task Force on Stability Terms and Definitions 9

Figure 2 – Example of step response. 15

Figure 3 – General interface between WT model, grid model and WP model.....	23
Figure 4 – General interface for initialisation of WT model, WP model and grid model.	25
Figure 5 – Generic modular structure of WT models.....	26
Figure 6 – Main electrical and mechanical components of type 1 WTs	26
Figure 7 – Modular structure for the type 1A WT model.....	27
Figure 8 – Modular structure for the type 1B WT model.....	28
Figure 9 – Main electrical and mechanical components of type 2 WTs	29
Figure 10 – Modular structure for the type 2 WT model.....	29
Figure 11 – Modular structure for the type 2 control model.....	30
Figure 12 – Main electrical and mechanical components of type 3 WTs	31
Figure 13 – Modular structure for the type 3 WT model	31
Figure 14 – Modular structure for the type 3 control models	32
Figure 15 – Main electrical and mechanical components of type 4 WTs	33
Figure 16 – Modular structure for the type 4A WT model.....	34
Figure 17 – Modular structure for the type 4A control model	34
Figure 18 – Modular structure for the type 4B WT model.....	35
Figure 19 – Modular structure for the type 4B control model	36
Figure 20 – Block diagram for constant aerodynamic torque model.....	37
Figure 21 – Block diagram for one-dimensional aerodynamic model	37
Figure 22 – Block diagram for two-dimensional aerodynamic model.....	38
Figure 23 – Block diagram for two mass model.....	39
Figure 24 – Block diagram for type 3A generator set model	40
Figure 25 – Block diagram for type 3B generator set model	42
Figure 26 – Block diagram for type 4 generator set model.....	43
Figure 27 – Block diagram for the reference frame rotation model.....	44
Figure 28 – Block diagram for pitch control power model	45
Figure 29 – Block diagram for pitch angle control model	46
Figure 30 – Block diagram for rotor resistance control model	47
Figure 31 – Block diagram for type 3 P control model	48
Figure 32 – Block diagram for type 3 torque PI	49
Figure 33 – Block diagram for type 4A P control model	49
Figure 34 – Block diagram for type 4B P control model	50
Figure 35 – Block diagram for Q control model.....	52
Figure 36 – Block diagram for current limiter.....	54
Figure 37 – Block diagram for constant Q limitation model.....	54
Figure 38 – Block diagram for QP and QU limitation model.....	55
Figure 39 – Block diagram for grid protection system	56
Figure 40 – Block diagram for u-f measurement.....	57
Figure 41 – Signal processing structure with "play-back" method applied.....	60
Figure 42 – Signal processing structure with "full grid simulation" method applied.	61
Figure 43 – Voltage dip windows.....	63
Figure D.1 – Block diagram for WP reactive power controllers	74
Figure D.2 – Block diagram for WP active power controller	75

Figure E.1 – Aerodynamic power as function of blade angle θ and wind speed v	77
Figure E.2 – Partial derivative of power with respect to rotor speed change $\partial p_{\text{aero}}/\partial \omega_{\text{WTR}}$ as function of blade angle θ and wind speed v	77
Figure E.3 – Partial derivative of power with respect to blade angle dp_{θ} as function of blade angle θ	78
Figure E.4 – Partial derivative of power with respect to rotor speed change dp_{ω} as function of wind speed v for 1 p.u. (solid line) and 0,5 p.u. (dashed line) active power	78
Figure E.5 – Approximation of aerodynamic power as function of wind speed	79
Figure E.6 – Approximation of the blade angle as function of wind speed	79
Figure F.1 – Sequence of Simulation on use of ESE-interface	85
Figure G.1 – Block symbol for single integration time step delay	86
Figure G.2 – Block symbol for stand-alone ramp rate limiter	86
Figure G.3 – Block diagram for implementation of the stand-alone ramp rate limiter	87
Figure G.4 – Block symbol for first order filter with absolute limits, rate limits and freeze flag	87
Figure G.5 – Block diagram for implementation of the first order filter with absolute limits, rate limits and freeze state	87
Figure G.6 – Block diagram for implementation of the freeze state without filter ($T = 0$)	88
Figure G.7 – Block symbol for lookup table	88
Figure G.8 – Block symbols for comparators	88
Figure G.9 – Block symbol for timer	89
Figure G.10 – Function of timer	89
Figure G.11 – Block symbol for anti windup integrator	89
Figure G.12 – Block diagram for implementation of anti windup integrator	90
Figure G.13 – Block symbol for integrator with reset	90
Figure G.14 – Block symbol for first order filter with limitation detection	90
Figure G.15 – Block diagram for implementation of first order filter with limitation detection	91
Figure G.16 – Block symbol for delay flag	91
Figure G.17 – Block diagram for implementation of delay flag	91
Figure G.18 – Block symbol raising edge detection	92
Figure G.19 – Block diagram for raising edge detection	92
Table 1 – Global WT model parameters	24
Table 2 – Initialisation variable used explicitly in model block diagrams	25
Table 3 – Modules used in type 1A model	27
Table 4 – Modules used in type 1B model	28
Table 5 – Modules used in type 2 model	30
Table 6 – Modules used in type 3 model	32
Table 7 – Modules used in type 4A model	35
Table 8 – Modules used in type 4B model	36
Table 9 – Parameter list for one-dimensional aerodynamic model	37
Table 10 – Parameter list for two-dimensional aerodynamic model	37
Table 11 – Parameter list for two-mass model	39
Table 12 – Parameter list for type 3A generator set model	40

Table 13 – Parameter list for type 3B generator set model	41
Table 14 – Parameter list for type 4 generator set model	43
Table 15 – Parameter list for reference frame rotation model	43
Table 16 – Parameter list for pitch control power model	44
Table 17 – Parameter list for pitch angle control model	45
Table 18 – Parameter list for rotor resistance control model	46
Table 19 – Parameter list for p control model type 3	47
Table 20 – Parameter list for p control model type 4A	49
Table 21 – Parameter list for p control model type 4B	50
Table 22 – General WT Q control modes M_{qG}	50
Table 23 – UVRT Q control modes M_{qUVRT}	51
Table 24 – Parameter list for q control model	51
Table 25 – Description of F_{UVRT} flag values	53
Table 26 – Parameter list for current limiter model	53
Table 27 – Parameter list for constant Q limitation model	54
Table 28 – Parameter list for QP and QU limitation model	55
Table 29 – Parameter list for grid protection model	56
Table 30 – Windows applied for error calculations	63
Table A.1 – Required information about simulation model and validation setup	66
Table A.2 – Additional information required if full grid method is applied	66
Table A.3 – Validation summary for voltage dips	67
Table A.4 – Validation summary for reference point changes	68
Table A.5 – Validation summary for grid protection	68
Table D.1 – Parameters used in the voltage and reactive power control model	73
Table D.2 – Parameters used in the frequency and active power control model	74
Table E.1 – Points characterising the relation between the wind speed v and the partial derivative dp_{ω}	78
Table E.2 – Parameter list for the aerodynamics of a specific WT type	79

INTERNATIONAL ELECTROTECHNICAL COMMISSION

WIND TURBINES –

**Part 27-1: Electrical simulation models –
Wind turbines**

FOREWORD

- 1) The International Electrotechnical Commission (IEC) is a worldwide organization for standardization comprising all national electrotechnical committees (IEC National Committees). The object of IEC is to promote international co-operation on all questions concerning standardization in the electrical and electronic fields. To this end and in addition to other activities, IEC publishes International Standards, Technical Specifications, Technical Reports, Publicly Available Specifications (PAS) and Guides (hereafter referred to as “IEC Publication(s)”). Their preparation is entrusted to technical committees; any IEC National Committee interested in the subject dealt with may participate in this preparatory work. International, governmental and non-governmental organizations liaising with the IEC also participate in this preparation. IEC collaborates closely with the International Organization for Standardization (ISO) in accordance with conditions determined by agreement between the two organizations.
- 2) The formal decisions or agreements of IEC on technical matters express, as nearly as possible, an international consensus of opinion on the relevant subjects since each technical committee has representation from all interested IEC National Committees.
- 3) IEC Publications have the form of recommendations for international use and are accepted by IEC National Committees in that sense. While all reasonable efforts are made to ensure that the technical content of IEC Publications is accurate, IEC cannot be held responsible for the way in which they are used or for any misinterpretation by any end user.
- 4) In order to promote international uniformity, IEC National Committees undertake to apply IEC Publications transparently to the maximum extent possible in their national and regional publications. Any divergence between any IEC Publication and the corresponding national or regional publication shall be clearly indicated in the latter.
- 5) IEC itself does not provide any attestation of conformity. Independent certification bodies provide conformity assessment services and, in some areas, access to IEC marks of conformity. IEC is not responsible for any services carried out by independent certification bodies.
- 6) All users should ensure that they have the latest edition of this publication.
- 7) No liability shall attach to IEC or its directors, employees, servants or agents including individual experts and members of its technical committees and IEC National Committees for any personal injury, property damage or other damage of any nature whatsoever, whether direct or indirect, or for costs (including legal fees) and expenses arising out of the publication, use of, or reliance upon, this IEC Publication or any other IEC Publications.
- 8) Attention is drawn to the Normative references cited in this publication. Use of the referenced publications is indispensable for the correct application of this publication.
- 9) Attention is drawn to the possibility that some of the elements of this IEC Publication may be the subject of patent rights. IEC shall not be held responsible for identifying any or all such patent rights.

International Standard IEC 61400-27-1 has been prepared IEC Technical Committee 88: Wind turbines.

The text of this draft is based on the following documents:

Enquiry draft	Report on voting
88/510/FDIS	88/529/RVD

Full information on the voting for the approval of this technical specification can be found in the report on voting indicated in the above table.

This publication has been drafted in accordance with the ISO/IEC Directives, Part 2.

A list of all parts in the IEC 61400 series, published under the general title *Wind turbines*, can be found on the IEC website.

The committee has decided that the contents of this publication will remain unchanged until the stability date indicated on the IEC web site under "<http://webstore.iec.ch>" in the data related to the specific publication. At this date, the publication will be

- reconfirmed,
- withdrawn,
- replaced by a revised edition, or
- amended.

IMPORTANT – The 'colour inside' logo on the cover page of this publication indicates that it contains colours which are considered to be useful for the correct understanding of its contents. Users should therefore print this document using a colour printer.

Withdrawn

INTRODUCTION

The IEC 61400-27 series specifies standard dynamic electrical simulation models for wind power generation. IEC 61400-27-1 specifies wind turbine models and model validation procedure. IEC 61400-27-2 will specify wind power plant models and model validation procedure.

The increasing penetration of wind energy in power systems implies that Transmission System Operators (TSOs) and Distribution System Operators (DSOs) need to use dynamic models of wind power generation for power system stability studies. The models developed by the wind turbine manufacturers reproduce the behaviour of their machines with a high level of detail. Such level of detail is not suitable for stability studies of large power systems with a huge number of wind power plants, firstly because the high level of detail increases the complexity and thus computer time dramatically, and secondly because the use of detailed manufacturer specific models requires a substantial amount of input data to represent the individual wind turbine types.

The purpose of this standard is to specify generic dynamic models, which can be applied in power system stability studies. The IEEE/CIGRE Joint Task Force on Stability Terms and Definitions has classified power system stability in categories according to Figure 1.

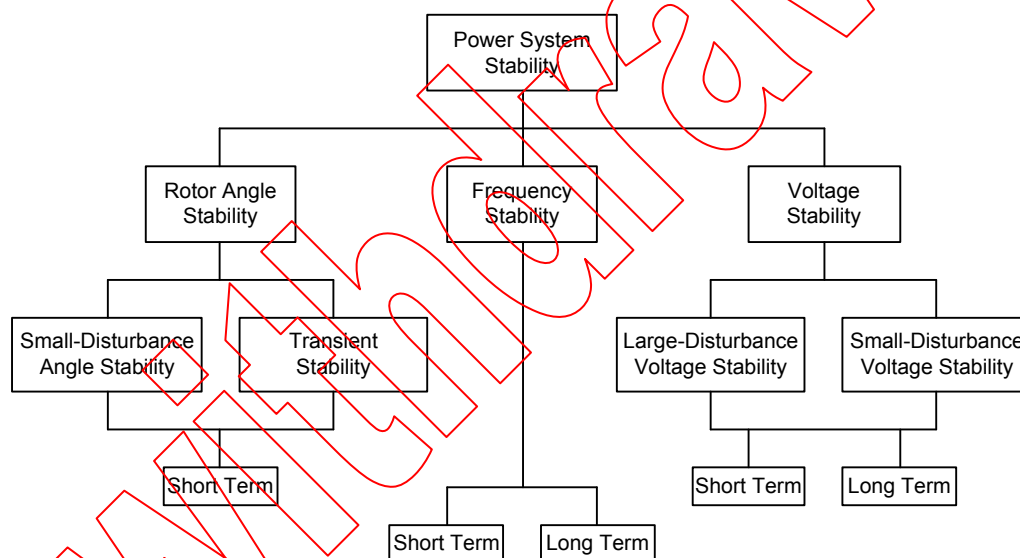

© IEEE 2004
IEC

Figure 1 – Classification of power system stability according to IEEE/CIGRE Joint Task Force on Stability Terms and Definitions

Referring to these categories, the models are developed to represent wind power generation in studies of large-disturbance short term voltage stability phenomena, but they will also be applicable to study other dynamic short term phenomena such as rotor angle stability, frequency stability and small-disturbance voltage stability. Thus, the models are applicable for dynamic simulations of power system events such as short-circuits (low voltage ride through), loss of generation or loads, and system separation of one synchronous area into more synchronous areas as specified in the scope.

The models have to be complete enough to represent the dynamic behaviour at the wind turbine terminals, but must also be suitable for large-scale grid studies. Therefore simplified wind turbine models are specified to perform the typical response of known wind turbine technologies.

The wind turbine models specified in this standard are for fundamental frequency positive sequence response¹. The models have the following limitations:

- The models are not intended for long term stability analysis.
- The models are not intended for investigation of sub-synchronous interaction phenomena.
- The models are not intended for investigation of the fluctuations originating from wind speed variability in time and space. This implies that the models do not include phenomena such as turbulence, tower shadow, wind shear and wakes.
- The models do not cover phenomena such as harmonics, flicker or any other EMC emissions included in the IEC 61000 series.
- The models have not been developed explicitly with eigenvalue calculation (for small signal stability) in mind².
- The models specified here apply only to wind turbines, and therefore do not include wind power plant level controls and additional equipment such as SVCs, STATCOMs and other devices which will be covered by IEC 61400-27-2. The wind turbine models interface to the wind power plant controller models in IEC 61400-27-2.
- This standard does not address the specifics of short-circuit calculations.
- The models are not applicable to studies of extremely weak systems including situations where wind turbines are islanded without other synchronous generation.
- The models are limited by the technical specifications in 5.2.

The validation procedure specified in this standard is intended to be applied to standard models and other fundamental frequency wind turbine models. The validation procedure has the following limitations:

- The validation procedure does not specify any requirements to model accuracy. It only specifies measures to quantify the accuracy of the model³.
- The validation procedure does not specify test and measurement procedures, as it is based on tests specified in IEC 61400-21.
- The simulation model validation is not intended to justify compliance to any grid code requirement, power quality requirements or national legislation.
- The test and measurement procedures introduce errors which limit the possible accuracy as specified in the validation procedure.
- The validation procedure does not include steady state validation, but focuses on validation of the dynamic performance of the model.

The following stakeholders are potential users of the models specified in this standard:

- TSOs and DSOs are end users of the models, performing power system stability studies as part of the planning as well as the operation of the power systems.
- Wind plant owners are typically responsible to provide the wind power plant models to TSO and/or DSO prior to plant commissioning.
- wind turbine manufacturers will typically provide the wind turbine models to the owner.

¹ This standard is dealing with balanced as well as unbalanced faults, but for unbalanced faults, only the positive sequence components are specified.

² These wind generation systems are highly non-linear and simplifications have been made in the development of the proposed models. Thus, linearisation for eigenvalue analysis is not trivial nor necessarily appropriate based on these simplified models.

³ Clause 6 specifies a large number of measures for model accuracy. The importance of the individual measure depends on the type of grid and type of stability study. Annex B describes limits to the possible accuracy of the models.

- Developers of modern software for power system simulation tools will use the standard to implement standard wind power models as part of the software library.
- Certification bodies in case of independent wind turbine model validation.
- Education and research communities, who can also benefit from the generic models, as the manufacturer specific models are typically confidential.

Withdrawn