

# INTERNATIONAL STANDARD

## NORME INTERNATIONALE

**Engineering data exchange format for use in industrial automation systems  
engineering – Automation markup language –  
Part 2: Role class libraries**

**Format d'échange de données techniques pour une utilisation dans l'ingénierie  
des systèmes d'automatisation industrielle – Automation markup language –  
Partie 2: Bibliothèques de classes de rôles**



## THIS PUBLICATION IS COPYRIGHT PROTECTED

Copyright © 2015 IEC, Geneva, Switzerland

All rights reserved. Unless otherwise specified, no part of this publication may be reproduced or utilized in any form or by any means, electronic or mechanical, including photocopying and microfilm, without permission in writing from either IEC or IEC's member National Committee in the country of the requester. If you have any questions about IEC copyright or have an enquiry about obtaining additional rights to this publication, please contact the address below or your local IEC member National Committee for further information.

Droits de reproduction réservés. Sauf indication contraire, aucune partie de cette publication ne peut être reproduite ni utilisée sous quelque forme que ce soit et par aucun procédé, électronique ou mécanique, y compris la photocopie et les microfilms, sans l'accord écrit de l'IEC ou du Comité national de l'IEC du pays du demandeur. Si vous avez des questions sur le copyright de l'IEC ou si vous désirez obtenir des droits supplémentaires sur cette publication, utilisez les coordonnées ci-après ou contactez le Comité national de l'IEC de votre pays de résidence.

IEC Central Office  
3, rue de Varembe  
CH-1211 Geneva 20  
Switzerland

Tel.: +41 22 919 02 11  
Fax: +41 22 919 03 00  
[info@iec.ch](mailto:info@iec.ch)  
[www.iec.ch](http://www.iec.ch)

### About the IEC

The International Electrotechnical Commission (IEC) is the leading global organization that prepares and publishes International Standards for all electrical, electronic and related technologies.

### About IEC publications

The technical content of IEC publications is kept under constant review by the IEC. Please make sure that you have the latest edition, a corrigenda or an amendment might have been published.

#### IEC Catalogue - [webstore.iec.ch/catalogue](http://webstore.iec.ch/catalogue)

The stand-alone application for consulting the entire bibliographical information on IEC International Standards, Technical Specifications, Technical Reports and other documents. Available for PC, Mac OS, Android Tablets and iPad.

#### IEC publications search - [www.iec.ch/searchpub](http://www.iec.ch/searchpub)

The advanced search enables to find IEC publications by a variety of criteria (reference number, text, technical committee,...). It also gives information on projects, replaced and withdrawn publications.

#### IEC Just Published - [webstore.iec.ch/justpublished](http://webstore.iec.ch/justpublished)

Stay up to date on all new IEC publications. Just Published details all new publications released. Available online and also once a month by email.

#### Electropedia - [www.electropedia.org](http://www.electropedia.org)

The world's leading online dictionary of electronic and electrical terms containing more than 30 000 terms and definitions in English and French, with equivalent terms in 15 additional languages. Also known as the International Electrotechnical Vocabulary (IEV) online.

#### IEC Glossary - [std.iec.ch/glossary](http://std.iec.ch/glossary)

More than 60 000 electrotechnical terminology entries in English and French extracted from the Terms and Definitions clause of IEC publications issued since 2002. Some entries have been collected from earlier publications of IEC TC 37, 77, 86 and CISPR.

#### IEC Customer Service Centre - [webstore.iec.ch/csc](http://webstore.iec.ch/csc)

If you wish to give us your feedback on this publication or need further assistance, please contact the Customer Service Centre: [csc@iec.ch](mailto:csc@iec.ch).

### A propos de l'IEC

La Commission Electrotechnique Internationale (IEC) est la première organisation mondiale qui élabore et publie des Normes internationales pour tout ce qui a trait à l'électricité, à l'électronique et aux technologies apparentées.

### A propos des publications IEC

Le contenu technique des publications IEC est constamment revu. Veuillez vous assurer que vous possédez l'édition la plus récente, un corrigendum ou amendement peut avoir été publié.

#### Catalogue IEC - [webstore.iec.ch/catalogue](http://webstore.iec.ch/catalogue)

Application autonome pour consulter tous les renseignements bibliographiques sur les Normes internationales, Spécifications techniques, Rapports techniques et autres documents de l'IEC. Disponible pour PC, Mac OS, tablettes Android et iPad.

#### Recherche de publications IEC - [www.iec.ch/searchpub](http://www.iec.ch/searchpub)

La recherche avancée permet de trouver des publications IEC en utilisant différents critères (numéro de référence, texte, comité d'études,...). Elle donne aussi des informations sur les projets et les publications remplacées ou retirées.

#### IEC Just Published - [webstore.iec.ch/justpublished](http://webstore.iec.ch/justpublished)

Restez informé sur les nouvelles publications IEC. Just Published détaille les nouvelles publications parues. Disponible en ligne et aussi une fois par mois par email.

#### Electropedia - [www.electropedia.org](http://www.electropedia.org)

Le premier dictionnaire en ligne de termes électroniques et électriques. Il contient plus de 30 000 termes et définitions en anglais et en français, ainsi que les termes équivalents dans 15 langues additionnelles. Egalement appelé Vocabulaire Electrotechnique International (IEV) en ligne.

#### Glossaire IEC - [std.iec.ch/glossary](http://std.iec.ch/glossary)

Plus de 60 000 entrées terminologiques électrotechniques, en anglais et en français, extraites des articles Termes et Définitions des publications IEC parues depuis 2002. Plus certaines entrées antérieures extraites des publications des CE 37, 77, 86 et CISPR de l'IEC.

#### Service Clients - [webstore.iec.ch/csc](http://webstore.iec.ch/csc)

Si vous désirez nous donner des commentaires sur cette publication ou si vous avez des questions contactez-nous: [csc@iec.ch](mailto:csc@iec.ch).

# INTERNATIONAL STANDARD

# NORME INTERNATIONALE



**Engineering data exchange format for use in industrial automation systems  
engineering – Automation markup language –  
Part 2: Role class libraries**

**Format d'échange de données techniques pour une utilisation dans l'ingénierie  
des systèmes d'automatisation industrielle – Automation markup language –  
Partie 2: Bibliothèques de classes de rôles**

INTERNATIONAL  
ELECTROTECHNICAL  
COMMISSION

COMMISSION  
ELECTROTECHNIQUE  
INTERNATIONALE

ICS 25.040.40; 35.06; 35.240.50

ISBN 978-2-8322-2407-6

**Warning! Make sure that you obtained this publication from an authorized distributor.  
Attention! Veuillez vous assurer que vous avez obtenu cette publication via un distributeur agréé.**

## CONTENTS

FOREWORD.....	7
INTRODUCTION.....	9
1 Scope.....	11
2 Normative references .....	11
3 Terms, definitions and abbreviations .....	11
3.1 Terms and definitions.....	11
3.2 Abbreviations .....	12
4 Conformity.....	12
5 AML role classes .....	13
5.1 Structure and references.....	13
5.2 AML role class library for discrete manufacturing industry – AutomationMLDMIRoleClassLib .....	14
5.2.1 General .....	14
5.2.2 RoleClass DiscManufacturingEquipment.....	15
5.2.3 RoleClass Transport.....	16
5.2.4 RoleClass Storage.....	16
5.2.5 RoleClass Fixture .....	16
5.2.6 RoleClass Gate .....	16
5.2.7 RoleClass Robot.....	17
5.2.8 RoleClass Tool.....	17
5.2.9 RoleClass Carrier.....	17
5.2.10 RoleClass Machine.....	17
5.2.11 RoleClass StaticObject .....	18
5.3 AML role class library for continuous manufacturing industry – AutomationMLCMIRoleClassLib .....	18
5.3.1 General .....	18
5.3.2 RoleClass ContManufacturingEquipment.....	19
5.4 AML role class library for batch manufacturing industry – AutomationMLBMRoleClassLib .....	19
5.4.1 General .....	19
5.4.2 RoleClass BatchManufacturingEquipment.....	20
5.5 AML role class library for control systems – AutomationMLCSRoleClassLib.....	20
5.5.1 General .....	20
5.5.2 RoleClass ControlEquipment.....	21
5.5.3 RoleClass Communication.....	22
5.5.4 RoleClass ControlHardware.....	22
5.5.5 RoleClass PC.....	22
5.5.6 RoleClass IPC .....	22
5.5.7 RoleClass Handheld .....	22
5.5.8 RoleClass EmbeddedDevice.....	23
5.5.9 RoleClass Sensor.....	23
5.5.10 RoleClass Actuator.....	23
5.5.11 RoleClass Controller.....	23
5.5.12 RoleClass PLC .....	24
5.5.13 RoleClass NC.....	24
5.5.14 RoleClass RC.....	24

5.5.15	RoleClass PAC .....	24
Annex A (informative)	AML extended role class library .....	25
A.1	General .....	25
A.2	RoleClass PLCFacet .....	26
A.3	RoleClass HMIFacet .....	27
A.4	RoleClass Enterprise .....	27
A.5	RoleClass Site .....	28
A.6	RoleClass Area .....	28
A.7	RoleClass ProductionLine .....	29
A.8	RoleClass WorkCell .....	29
A.9	RoleClass ProcessCell .....	29
A.10	RoleClass Unit .....	30
A.11	RoleClass ProductionUnit .....	30
A.12	RoleClass StorageZone .....	30
A.13	RoleClass StorageUnit .....	31
A.14	RoleClass Turntable .....	31
A.15	RoleClass Conveyor .....	31
A.16	RoleClass BeltConveyor .....	32
A.17	RoleClass RollConveyor .....	32
A.18	RoleClass ChainConveyor .....	32
A.19	RoleClass PalletConveyor .....	32
A.20	RoleClass OverheadConveyor .....	33
A.21	RoleClass LiftingTable .....	33
A.22	RoleClass AGV .....	33
A.23	RoleClass Transposer .....	33
A.24	RoleClass CarrierHandlingSystem .....	34
A.25	RoleClass BodyStore .....	34
A.26	RoleClass Lift .....	34
A.27	RoleClass Rollerbed .....	34
A.28	RoleClass StationaryTool .....	35
A.29	RoleClass MovableTool .....	35
A.30	RoleClass ControlCabinet .....	35
A.31	RoleClass IODevice .....	35
A.32	RoleClass HMI .....	36
A.33	RoleClass WarningEquipment .....	36
A.34	RoleClass ActuatingDrive .....	36
A.35	RoleClass MotionController .....	36
A.36	RoleClass Panel .....	37
A.37	RoleClass MeasuringEquipment .....	37
A.38	RoleClass Clamp .....	37
A.39	RoleClass ProcessController .....	37
A.40	RoleClass Loader .....	38
A.41	RoleClass Unloader .....	38
Annex B (informative)	Examples of usage of RoleClasses .....	39
B.1	General .....	39
B.2	Example plant unit .....	39
Annex C (informative)	User-defined RoleClass libraries .....	44
C.1	General .....	44
C.2	External semantics of attributes .....	45

Annex D (informative) XML representation of AML libraries .....	46
D.1 AutomationMLDMIRoleClassLib .....	46
D.2 AutomationMLCMIRoleClassLib .....	46
D.3 AutomationMLBMIRoleClassLib .....	47
D.4 AutomationMLCSRoleClassLib .....	47
D.5 AutomationMLExtendedRoleClassLib .....	48
Bibliography .....	51
Figure 1 – Overview of the engineering data exchange format (AML) .....	9
Figure 2 – AutomationMLBaseRoleClassLib defined in IEC 62714-1:2014 .....	13
Figure 3 – AutomationMLDMIRoleClassLib .....	15
Figure 4 – XML grid of the AutomationMLDMIRoleClassLib .....	15
Figure 5 – XML text of the AutomationMLDMIRoleClassLib .....	15
Figure 6 – AutomationMLCMIRoleClassLib .....	18
Figure 7 – XML grid of the AutomationMLCMIRoleClassLib .....	18
Figure 8 – XML text of the AutomationMLCMIRoleClassLib .....	19
Figure 9 – AutomationMLBMIRoleClassLib .....	19
Figure 10 – XML grid of the AutomationMLBMIRoleClassLib .....	19
Figure 11 – XML text of the AutomationMLBMIRoleClassLib .....	19
Figure 12 – AutomationMLCSRoleClassLib .....	20
Figure 13 – XML grid of the AutomationMLCSRoleClassLib .....	21
Figure 14 – XML text of the AutomationMLCSRoleClassLib .....	21
Figure A.1 – AutomationMLExtendedRoleClassLib .....	26
Figure A.2 – Resource structure [SOURCE: IEC 62264-1:2013] .....	28
Figure B.1 – Usage of roles in the mapping process .....	39
Figure B.2 – Example for usage of roles .....	40
Figure B.3 – Example AML model .....	40
Figure B.4 – Example InstanceHierarchy for usage of roles .....	41
Figure B.5 – XML grid of the example InstanceHierarchy for usage of roles .....	41
Figure B.6 – XML text of the example InstanceHierarchy for usage of roles .....	41
Figure B.7 – External RoleClassLib reference .....	42
Figure B.8 – Usage of external role class in example .....	42
Figure B.9 – Example SystemUnitClass library for usage of roles .....	43
Figure B.10 – XML grid of the example SystemUnitClass library for usage of roles .....	43
Figure B.11 – XML text of the example SystemUnitClass library for usage of roles .....	43
Figure C.1 – AML user-defined RoleClassLib FoodAndBeverage .....	44
Figure C.2 – Example for external attribute semantics .....	45
Table 1 – Abbreviations .....	12
Table 2 – Structure of AML role class libraries .....	13
Table 3 – RoleClass DiscManufacturingEquipment .....	16
Table 4 – RoleClass Transport .....	16
Table 5 – RoleClass Storage .....	16
Table 6 – RoleClass Fixture .....	16

Table 7 – RoleClass Gate .....	17
Table 8 – RoleClass Robot .....	17
Table 9 – RoleClass Tool .....	17
Table 10 – RoleClass Carrier .....	17
Table 11 – RoleClass Machine .....	18
Table 12 – RoleClass StaticObject .....	18
Table 13 – RoleClass ContManufacturingEquipment .....	19
Table 14 – RoleClass BatchManufacturingEquipment .....	20
Table 15 – RoleClass ControlEquipment .....	21
Table 16 – RoleClass Communication .....	22
Table 17 – RoleClass ControlHardware .....	22
Table 18 – RoleClass PC .....	22
Table 19 – RoleClass IPC .....	22
Table 20 – RoleClass Handheld .....	23
Table 21 – RoleClass EmbeddedDevice .....	23
Table 22 – RoleClass Sensor .....	23
Table 23 – RoleClass Actuator .....	23
Table 24 – RoleClass Controller .....	23
Table 25 – RoleClass PLC .....	24
Table 26 – RoleClass NC .....	24
Table 27 – RoleClass RC .....	24
Table 28 – RoleClass PAC .....	24
Table A.1 – RoleClass PLCFacet .....	27
Table A.2 – RoleClass HMIFacet .....	27
Table A.3 – RoleClass Enterprise .....	27
Table A.4 – RoleClass Site .....	28
Table A.5 – RoleClass Area .....	29
Table A.6 – RoleClass ProductionLine .....	29
Table A.7 – RoleClass WorkCell .....	29
Table A.8 – RoleClass ProcessCell .....	30
Table A.9 – RoleClass Unit .....	30
Table A.10 – RoleClass ProductionUnit .....	30
Table A.11 – RoleClass StorageZone .....	31
Table A.12 – RoleClass StorageUnit .....	31
Table A.13 – RoleClass Turntable .....	31
Table A.14 – RoleClass Conveyor .....	32
Table A.15 – RoleClass BeltConveyor .....	32
Table A.16 – RoleClass RollConveyor .....	32
Table A.17 – RoleClass ChainConveyor .....	32
Table A.18 – RoleClass PalletConveyor .....	33
Table A.19 – RoleClass OverheadConveyor .....	33
Table A.20 – RoleClass LiftingTable .....	33
Table A.21 – RoleClass AGV .....	33

Table A.22 – RoleClass Transposer .....	34
Table A.23 – RoleClass CarrierHandlingSystem.....	34
Table A.24 – RoleClass BodyStore .....	34
Table A.25 – RoleClass Lift.....	34
Table A.26 – RoleClass Rollerbed .....	35
Table A.27 – RoleClass StationaryTool .....	35
Table A.28 – RoleClass MovableTool.....	35
Table A.29 – RoleClass ControlCabinet .....	35
Table A.30 – RoleClass IODevice .....	36
Table A.31 – RoleClass HMI .....	36
Table A.32 – RoleClass WarningEquipment .....	36
Table A.33 – RoleClass ActuatingDrive.....	36
Table A.34 – RoleClass MotionController.....	37
Table A.35 – RoleClass Panel .....	37
Table A.36 – RoleClass MeasuringEquipment.....	37
Table A.37 – RoleClass Clamp .....	37
Table A.38 – RoleClass ProcessController.....	38
Table A.39 – RoleClass Loader.....	38
Table A.40 – RoleClass Unloader .....	38

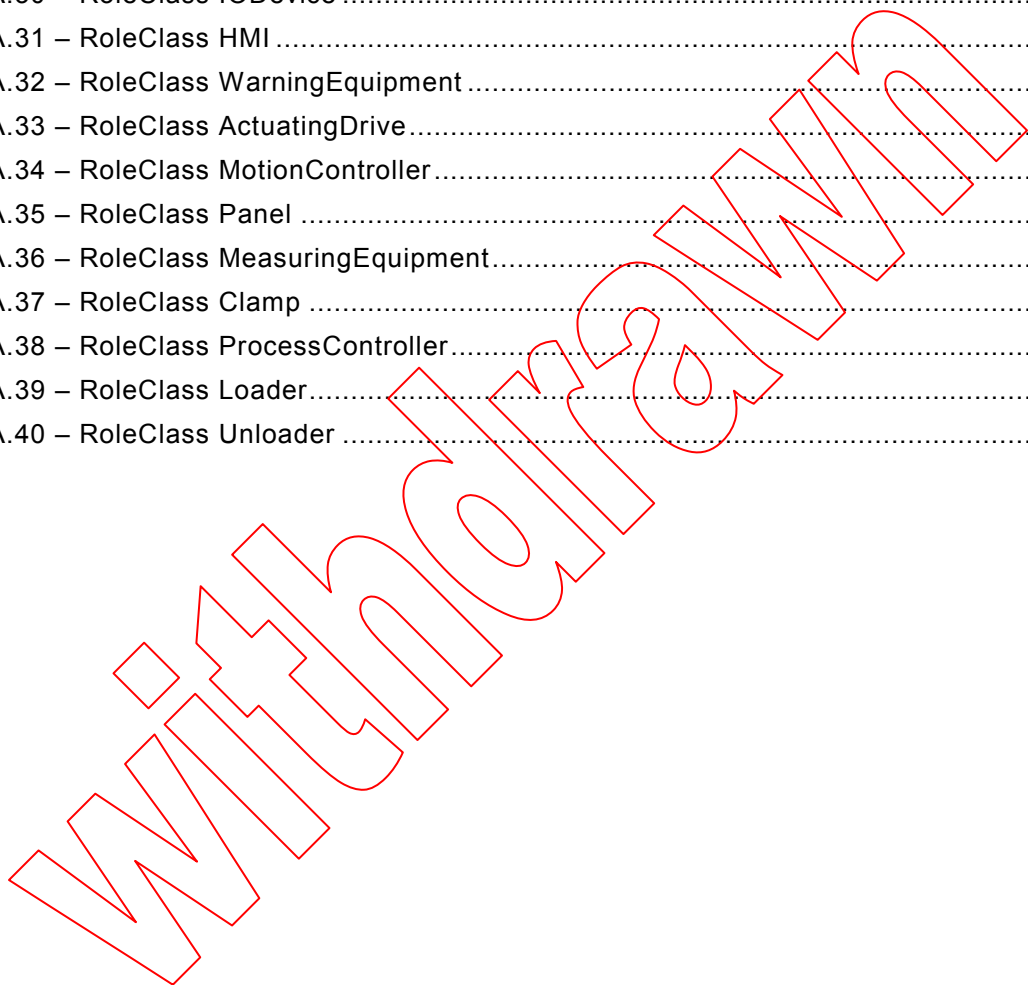

## INTERNATIONAL ELECTROTECHNICAL COMMISSION

**ENGINEERING DATA EXCHANGE FORMAT FOR USE  
IN INDUSTRIAL AUTOMATION SYSTEMS ENGINEERING –  
AUTOMATION MARKUP LANGUAGE –**

**Part 2: Role class libraries**

**FOREWORD**

- 1) The International Electrotechnical Commission (IEC) is a worldwide organization for standardization comprising all national electrotechnical committees (IEC National Committees). The object of IEC is to promote international co-operation on all questions concerning standardization in the electrical and electronic fields. To this end and in addition to other activities, IEC publishes International Standards, Technical Specifications, Technical Reports, Publicly Available Specifications (PAS) and Guides (hereafter referred to as "IEC Publication(s)"). Their preparation is entrusted to technical committees, any IEC National Committee interested in the subject dealt with may participate in this preparatory work. International, governmental and non-governmental organizations liaising with the IEC also participate in this preparation. IEC collaborates closely with the International Organization for Standardization (ISO) in accordance with conditions determined by agreement between the two organizations.
- 2) The formal decisions or agreements of IEC on technical matters express, as nearly as possible, an international consensus of opinion on the relevant subjects since each technical committee has representation from all interested IEC National Committees.
- 3) IEC Publications have the form of recommendations for international use and are accepted by IEC National Committees in that sense. While all reasonable efforts are made to ensure that the technical content of IEC Publications is accurate, IEC cannot be held responsible for the way in which they are used or for any misinterpretation by any end user.
- 4) In order to promote international uniformity, IEC National Committees undertake to apply IEC Publications transparently to the maximum extent possible in their national and regional publications. Any divergence between any IEC Publication and the corresponding national or regional publication shall be clearly indicated in the latter.
- 5) IEC itself does not provide any attestation of conformity. Independent certification bodies provide conformity assessment services and, in some areas, access to IEC marks of conformity. IEC is not responsible for any services carried out by independent certification bodies.
- 6) All users should ensure that they have the latest edition of this publication.
- 7) No liability shall attach to IEC or its directors, employees, servants or agents including individual experts and members of its technical committees and IEC National Committees for any personal injury, property damage or other damage of any nature whatsoever, whether direct or indirect, or for costs (including legal fees) and expenses arising out of the publication, use of, or reliance upon, this IEC Publication or any other IEC Publications.
- 8) Attention is drawn to the Normative references cited in this publication. Use of the referenced publications is indispensable for the correct application of this publication.
- 9) Attention is drawn to the possibility that some of the elements of this IEC Publication may be the subject of patent rights. IEC shall not be held responsible for identifying any or all such patent rights.

International Standard IEC 62714-2 has been prepared by subcommittee 65E: Devices and integration in enterprise systems, of IEC technical committee 65: Industrial-process measurement, control and automation.

The text of this standard is based on the following documents:

CDV	Report on voting
65E/300/CDV	65E/390/RVC

Full information on the voting for the approval of this standard can be found in the report on voting indicated in the above table.

This publication has been drafted in accordance with the ISO/IEC Directives, Part 2.

A list of all parts in the IEC 62714 series, published under the general title *Engineering data exchange format for use in industrial automation systems engineering – Automation Markup Language*, can be found on the IEC website.

The committee has decided that the contents of this publication will remain unchanged until the stability date indicated on the IEC website under "<http://webstore.iec.ch>" in the data related to the specific publication. At this date, the publication will be

- reconfirmed,
- withdrawn,
- replaced by a revised edition, or
- amended.

**IMPORTANT – The 'colour inside' logo on the cover page of this publication indicates that it contains colours which are considered to be useful for the correct understanding of its contents. Users should therefore print this document using a colour printer.**

Withdrawn

## INTRODUCTION

The data exchange format defined in IEC 62714 (Automation Markup Language, AML) is an XML schema based data format and has been developed in order to support the data exchange between engineering tools in a heterogeneous engineering tool landscape. IEC 62714-1 gives an overview about the format.

The goal of AML is to interconnect engineering tools from the existing heterogeneous tool landscape in their different disciplines, e.g. mechanical plant engineering, electrical design, process engineering, process control engineering, HMI development, PLC programming, robot programming, etc.

AML stores engineering information following the object oriented paradigm and allows modelling of physical and logical plant components as data objects encapsulating different aspects. An object may consist of other sub-objects and may itself be part of a larger composition or aggregation. Typical objects in plant automation comprise information on topology, geometry, kinematics and logic, whereas logic comprises sequencing, behaviour and control.

AML combines existing industry data formats that are designed for the storage and exchange of different aspects of engineering information. These data formats are used on “as-is” basis within their own specifications and are not branched for AML needs.

The core of AML is the top-level data format CAEX that connects the different data formats. Therefore, AML has an inherent distributed document architecture.

Figure 1 illustrates the basic AML architecture and the distribution of topology, geometry, kinematic and logic information.

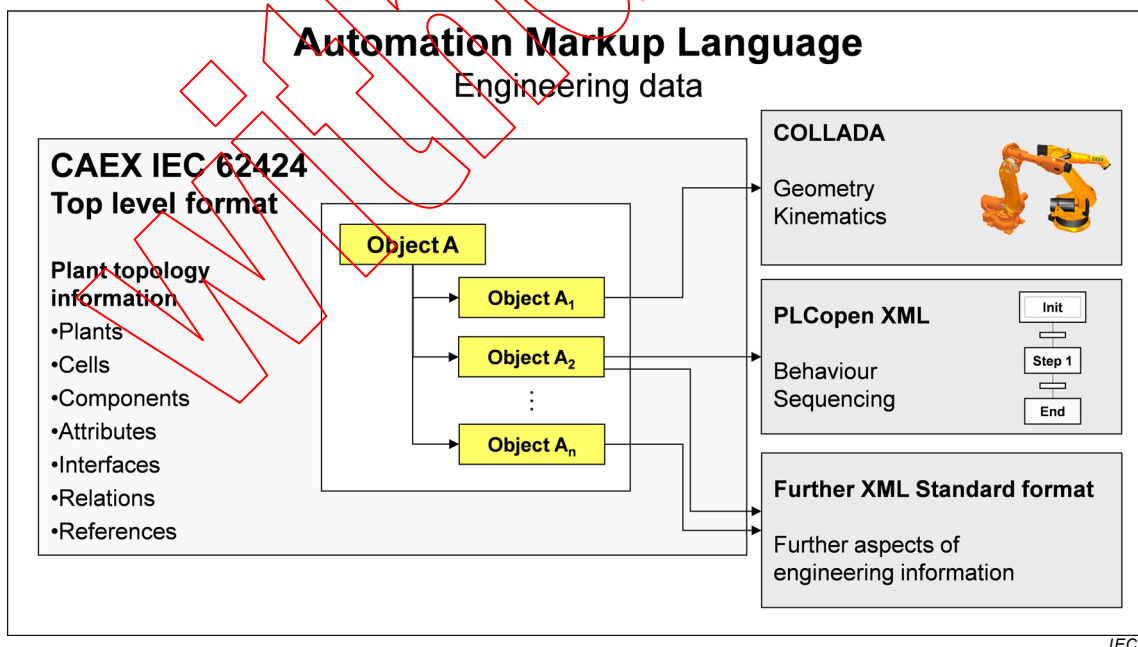

**Figure 1 – Overview of the engineering data exchange format (AML)**

Due to the different aspects of AML, IEC 62714 consists of different parts focussing on different aspects.

- IEC 62714-1: Architecture and general requirements

This part specifies the general AML architecture, the modelling of engineering data, classes, instances, relations, references, hierarchies, basic AML libraries and extended AML concepts.

- IEC 62714-2: Role class libraries

This part specifies additional AML libraries.

- IEC 62714-3<sup>1</sup>: Geometry and kinematics

This forthcoming part is intended to specify the modelling of geometry and kinematics information.

In addition, another part (possibly Part 4) will specify the modelling of logics, sequencing, behaviour and control related information.

Further parts may be added in the future in order to interconnect further data standards to AML.

Clause 5 describes normative role class libraries within AML.

Annex A describes the informative AML extended role class library.

Annex B gives an informative example for the usage of AML role classes.

Annex C shows some user-defined role class libraries of different origins.

Annex D gives an informative XML representation of the libraries defined in this part of IEC 62714.

---

<sup>1</sup> Under consideration.