

INTERNATIONAL STANDARD

NORME INTERNATIONALE

**Low-voltage switchgear and controlgear assemblies –
Part 5: Assemblies for power distribution in public networks**

**Ensembles d'appareillage à basse tension –
Partie 5: Ensembles pour réseaux de distribution publique**



THIS PUBLICATION IS COPYRIGHT PROTECTED
Copyright © 2010 IEC, Geneva, Switzerland

All rights reserved. Unless otherwise specified, no part of this publication may be reproduced or utilized in any form or by any means, electronic or mechanical, including photocopying and microfilm, without permission in writing from either IEC or IEC's member National Committee in the country of the requester.

If you have any questions about IEC copyright or have an enquiry about obtaining additional rights to this publication, please contact the address below or your local IEC member National Committee for further information.

Droits de reproduction réservés. Sauf indication contraire, aucune partie de cette publication ne peut être reproduite ni utilisée sous quelque forme que ce soit et par aucun procédé, électronique ou mécanique, y compris la photocopie et les microfilms, sans l'accord écrit de la CEI ou du Comité national de la CEI du pays du demandeur.

Si vous avez des questions sur le copyright de la CEI ou si vous désirez obtenir des droits supplémentaires sur cette publication, utilisez les coordonnées ci-après ou contactez le Comité national de la CEI de votre pays de résidence.

IEC Central Office
3, rue de Varembe
CH-1211 Geneva 20
Switzerland
Email: inmail@iec.ch
Web: www.iec.ch

About the IEC

The International Electrotechnical Commission (IEC) is the leading global organization that prepares and publishes International Standards for all electrical, electronic and related technologies.

About IEC publications

The technical content of IEC publications is kept under constant review by the IEC. Please make sure that you have the latest edition, a corrigenda or an amendment might have been published.

- Catalogue of IEC publications: www.iec.ch/searchpub

The IEC on-line Catalogue enables you to search by a variety of criteria (reference number, text, technical committee,...). It also gives information on projects, withdrawn and replaced publications.

- IEC Just Published: www.iec.ch/online_news/justpub

Stay up to date on all new IEC publications. Just Published details twice a month all new publications released. Available on-line and also by email.

- Electropedia: www.electropedia.org

The world's leading online dictionary of electronic and electrical terms containing more than 20 000 terms and definitions in English and French, with equivalent terms in additional languages. Also known as the International Electrotechnical Vocabulary online.

- Customer Service Centre: www.iec.ch/webstore/custserv

If you wish to give us your feedback on this publication or need further assistance, please visit the Customer Service Centre FAQ or contact us:

Email: csc@iec.ch

Tel.: +41 22 919 02 11

Fax: +41 22 919 03 00

A propos de la CEI

La Commission Electrotechnique Internationale (CEI) est la première organisation mondiale qui élabore et publie des normes internationales pour tout ce qui a trait à l'électricité, à l'électronique et aux technologies apparentées.

A propos des publications CEI

Le contenu technique des publications de la CEI est constamment revu. Veuillez vous assurer que vous possédez l'édition la plus récente, un corrigendum ou amendement peut avoir été publié.

- Catalogue des publications de la CEI: www.iec.ch/searchpub/cur_fut-f.htm

Le Catalogue en-ligne de la CEI vous permet d'effectuer des recherches en utilisant différents critères (numéro de référence, texte, comité d'études,...). Il donne aussi des informations sur les projets et les publications retirées ou remplacées.

- Just Published CEI: www.iec.ch/online_news/justpub

Restez informé sur les nouvelles publications de la CEI. Just Published détaille deux fois par mois les nouvelles publications parues. Disponible en-ligne et aussi par email.

- Electropedia: www.electropedia.org

Le premier dictionnaire en ligne au monde de termes électroniques et électriques. Il contient plus de 20 000 termes et définitions en anglais et en français, ainsi que les termes équivalents dans les langues additionnelles. Egalement appelé Vocabulaire Electrotechnique International en ligne.

- Service Clients: www.iec.ch/webstore/custserv/custserv_entry-f.htm

Si vous désirez nous donner des commentaires sur cette publication ou si vous avez des questions, visitez le FAQ du Service clients ou contactez-nous:

Email: csc@iec.ch

Tél.: +41 22 919 02 11

Fax: +41 22 919 03 00



IEC 61439-5

Edition 1.0 2010-11

INTERNATIONAL STANDARD

NORME INTERNATIONALE

**Low-voltage switchgear and controlgear assemblies –
Part 5: Assemblies for power distribution in public networks**

**Ensembles d'appareillage à basse tension –
Partie 5: Ensembles pour réseaux de distribution publique**

INTERNATIONAL
ELECTROTECHNICAL
COMMISSION

COMMISSION
ELECTROTECHNIQUE
INTERNATIONALE

PRICE CODE
CODE PRIX

U

ICS 29.130.20

ISBN 978-2-88912-266-0

CONTENTS

FOREWORD.....	3
1 Scope.....	5
2 Normative references.....	6
3 Terms and definitions.....	6
4 Symbols and abbreviations.....	7
5 Interface characteristics.....	7
6 Information.....	7
7 Service conditions.....	8
8 Constructional requirements.....	8
9 Performance requirements.....	11
10 Design verification.....	11
11 Routine verification.....	24
Annex AA (normative) Cross-section of conductors.....	25
Figure 101 – Typical distribution network.....	5
Figure 102 – Diagram of test to verify resistance to shock load of a PENDA-O.....	14
Figure 103 – Diagram of test to verify impact force withstand of a PENDA-O.....	15
Figure 104 – Diagram of test to verify the resistance to static load.....	16
Figure 105 – Sandbag for test to verify the resistance to shock load.....	17
Figure 106 – Diagram of test to verify resistance to torsional stress of a PENDA-O.....	18
Figure 107 – Diagram of test to verify the mechanical strength of doors.....	21
Figure 108 – Striker element for test of resistance to mechanical shock impacts induced by sharp-edged objects.....	22
Figure 109 – Typical test arrangement for mechanical strength of base.....	23
Table 101 – Values of assumed loading.....	7
Table 102 – Axial load to be applied to the inserts.....	21
Table AA.1 – Minimum and maximum cross-section of copper and aluminium conductors, suitable for connection (see 8.8).....	25
Table AA.2 – Standard cross-sections of round copper conductors and approximate relationship between mm ² and AWG/kcmil sizes (see 8.8 of Part 1).....	26

INTERNATIONAL ELECTROTECHNICAL COMMISSION

LOW-VOLTAGE SWITCHGEAR AND CONTROLGEAR ASSEMBLIES –**Part 5: Assemblies for power distribution in public networks**

FOREWORD

- 1) The International Electrotechnical Commission (IEC) is a worldwide organization for standardization comprising all national electrotechnical committees (IEC National Committees). The object of IEC is to promote international co-operation on all questions concerning standardization in the electrical and electronic fields. To this end and in addition to other activities, IEC publishes International Standards, Technical Specifications, Technical Reports, Publicly Available Specifications (PAS) and Guides (hereafter referred to as "IEC Publication(s)"). Their preparation is entrusted to technical committees; any IEC National Committee interested in the subject dealt with may participate in this preparatory work. International, governmental and non-governmental organizations liaising with the IEC also participate in this preparation. IEC collaborates closely with the International Organization for Standardization (ISO) in accordance with conditions determined by agreement between the two organizations.
- 2) The formal decisions or agreements of IEC on technical matters express, as nearly as possible, an international consensus of opinion on the relevant subjects since each technical committee has representation from all interested IEC National Committees.
- 3) IEC Publications have the form of recommendations for international use and are accepted by IEC National Committees in that sense. While all reasonable efforts are made to ensure that the technical content of IEC Publications is accurate, IEC cannot be held responsible for the way in which they are used or for any misinterpretation by any end user.
- 4) In order to promote international uniformity, IEC National Committees undertake to apply IEC Publications transparently to the maximum extent possible in their national and regional publications. Any divergence between any IEC Publication and the corresponding national or regional publication shall be clearly indicated in the latter.
- 5) IEC itself does not provide any attestation of conformity. Independent certification bodies provide conformity assessment services and, in some areas, access to IEC marks of conformity. IEC is not responsible for any services carried out by independent certification bodies.
- 6) All users should ensure that they have the latest edition of this publication.
- 7) No liability shall attach to IEC or its directors, employees, servants or agents including individual experts and members of its technical committees and IEC National Committees for any personal injury, property damage or other damage of any nature whatsoever, whether direct or indirect, or for costs (including legal fees) and expenses arising out of the publication, use of, or reliance upon, this IEC Publication or any other IEC Publications.
- 8) Attention is drawn to the Normative references cited in this publication. Use of the referenced publications is indispensable for the correct application of this publication.
- 9) Attention is drawn to the possibility that some of the elements of this IEC Publication may be the subject of patent rights. IEC shall not be held responsible for identifying any or all such patent rights.

International Standard IEC 61439-5 has been prepared by subcommittee 17D: Low-voltage switchgear and controlgear assemblies, of IEC technical committee 17: Switchgear and controlgear.

This first edition of IEC 61439-5 cancels and replaces the second edition of IEC 60439-5 (2006), and constitutes a technical revision.

This edition of IEC 61439-5 includes the following significant technical changes with respect to the latest edition of IEC 60439-5:

- alignment on IEC 61439-1 regarding the structure and technical content, as applicable;
- introduction of new verifications, accordingly;
- harmonisation of the requirements of substation cable distribution boards and cable distribution cabinets, thereby eliminating the need to identify and define two categories of assembly;
- simpler standard as a result of a reduction in the number of assembly types defined and the acronyms used to identify the different assemblies.

The text of this standard is based on the following documents:

FDIS	Report on voting
17D/422/FDIS	17D/430/RVD

Full information on the voting for the approval of this standard can be found in the report on voting indicated in the above table.

This publication has been drafted in accordance with the ISO/IEC Directives, Part 2.

This standard is to be read in conjunction with IEC 61439-1. The provisions of the general rules dealt with in IEC 61439-1 (hereinafter referred to as Part 1) are only applicable to this standard insofar as they are specifically cited. When this standard states “addition”, “modification” or “replacement”, the relevant text in Part 1 is to be adapted accordingly.

Subclauses that are numbered with a 101 (102, 103 etc.) suffix are additional to the same subclause in Part 1.

Tables and figures in this Part 5 that are new are numbered starting with 101.

New annexes in this Part 5 are lettered AA, BB, etc.

In this standard, terms written in small capitals are defined in Clause 3.

A list of all parts of the IEC 61439 series, under the general title *Low-voltage switchgear and controlgear assemblies* can be found on the IEC website.

The committee has decided that the contents of this publication will remain unchanged until the stability date indicated on the IEC web site under "<http://webstore.iec.ch>" in the data related to the specific publication. At this date, the publication will be

- reconfirmed,
- withdrawn,
- replaced by a revised edition, or
- amended.

LOW-VOLTAGE SWITCHGEAR AND CONTROLGEAR ASSEMBLIES –

Part 5: Assemblies for power distribution in public networks

1 Scope

This clause of Part 1 applies with the following additions.

Addition:

This standard gives specific requirements for public electricity network distribution assemblies (PENDAs), which are stationary assemblies verified by verification tests, as defined in this standard. These ASSEMBLIES are used for the distribution of electrical energy in three-phase systems (see Figure 101 for a typical distribution network). Open type ASSEMBLIES are not covered by this standard.

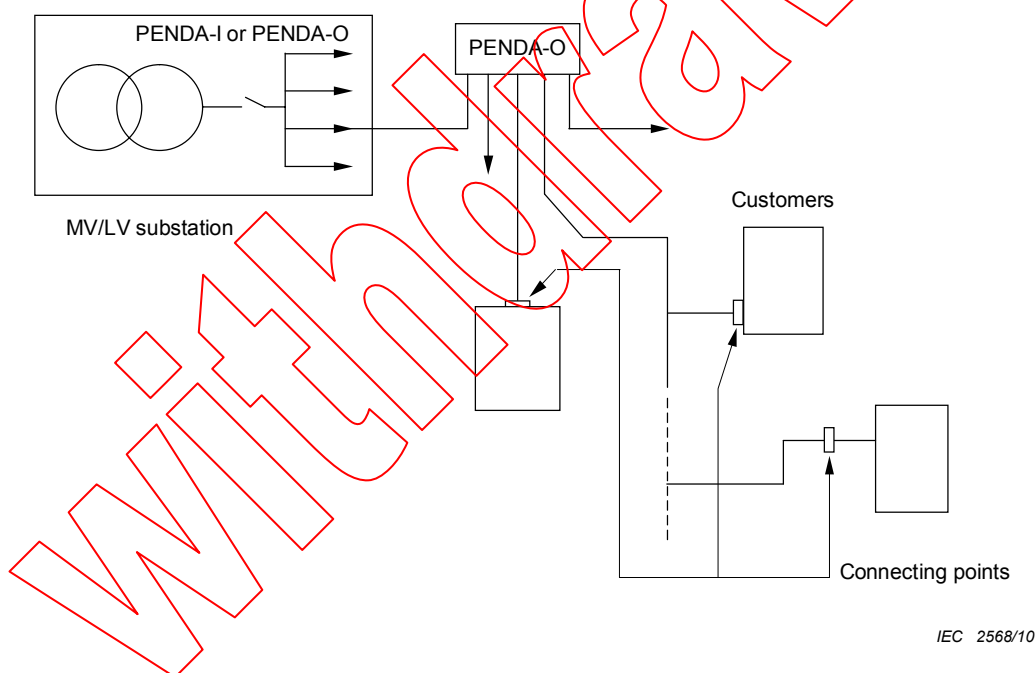

Figure 101 – Typical distribution network

The object of this standard is to state the definitions and to specify the service conditions, construction requirements, technical characteristics and tests for PENDAs. Network parameters may require tests at higher performance levels.

NOTE 1 If a PENDA is equipped with additional equipment (for example meters), in such a way that the main function is changed considerably, then other standards may also apply as agreed between user and manufacturer (see 8.5).

NOTE 2 Where local regulations and practices permit, a PENDA according to this standard may be used in other than public networks.

PENDAs are suitable for installation in places where only skilled persons have access for their use, however, outdoor types may be installed in situations that are accessible to ordinary persons.